

Configurable rotary actuator fail-safe and extended functionalities for adjusting dampers in technical building installations and in laboratories

- Air damper size up to approx. 1.2 m<sup>2</sup>
- Torque motor 6 Nm
- Nominal voltage AC/DC 24 V
- Control modulating 2...10 V variable
- Position feedback 2...10 V variable
- Running time motor 4 s variable

**Technical data**

<b>Electrical data</b>	Nominal voltage	AC/DC 24 V
	Nominal voltage frequency	50/60 Hz
	Nominal voltage range	AC 19.2...28.8 V / DC 21.6...28.8 V
	Power consumption in operation	11 W
	Power consumption in rest position	3 W
	Power consumption for wire sizing	22 VA
	Power consumption for wire sizing note	I <sub>max</sub> 20 A @ 5 ms
	Connection supply / control	Cable 1 m, 4 x 0.75 mm <sup>2</sup>
	Parallel operation	Yes (note the performance data)
	<b>Functional data</b>	Torque motor
Operating range Y		2...10 V
Input Impedance		100 kΩ
Options positioning signal		Open/close Modulating (DC 0...32 V)
Operating range Y variable		Start point 0.5...30 V End point 2.5...32 V
Position feedback U		2...10 V
Position feedback U note		Max. 0.5 mA
Position feedback U variable		Start point 0.5...8 V End point 2.5...10 V
Setting fail-safe position		0...100%, adjustable in increments of 10% (POP rotary knob on 0 corresponds to left end stop)
Bridging time (PF)		0 s
Bridging time (PF) variable		0...5 s
Position accuracy		±5%
Direction of motion motor		selectable with switch 0/1
Direction of motion note		Y = 0 V: At switch position 0 (ccw rotation) / 1 (cw rotation)
Direction of motion variable		electronically reversible
Direction of motion fail-safe		selectable with switch 0...100%
Manual override		with push-button
Angle of rotation		Max. 95°
Angle of rotation note		can be limited on both sides with adjustable mechanical end stops
Minimum angle of rotation		Min. 30°
Running time motor		4 s / 90°
Running time motor variable		4...20 s
Running time fail-safe		4 s / 90°
Running time fail-safe note		<4 s @ 0...50°C
Adaptation setting range		manual (automatic on first power-up)
Adaptation setting range variable		No action Adaptation when switched on Adaptation after pushing the gear disengagement button
Override control	MAX (maximum position) = 100% MIN (minimum position) = 0% ZS (intermediate position, AC only) = 50%	

## Technical data

<b>Functional data</b>	Override control variable	MAX = (MIN + 32%)...100% MIN = 0%...(MAX - 32%) ZS = MIN...MAX
	Sound power level, motor	60 dB(A)
	Sound power level, fail-safe	60 dB(A)
	Mechanical interface	Universal shaft clamp 8...26.7 mm
	Position indication	Mechanically, pluggable
<b>Safety</b>	Protection class IEC/EN	III Safety Extra-Low Voltage (SELV)
	Protection class UL	UL Class 2 Supply
	Degree of protection IEC/EN	IP54
	Degree of protection NEMA/UL	NEMA 2
	Enclosure	UL Enclosure Type 2
	EMC	CE according to 2014/30/EU
	Certification IEC/EN	IEC/EN 60730-1 and IEC/EN 60730-2-14
	Certification UL	cULus according to UL60730-1A, UL60730-2-14 and CAN/CSA E60730-1:02
	Certification UL note	The UL marking on the actuator depends on the production site, the device is UL-compliant in any case
	Mode of operation	Type 1.AA
	Rated impulse voltage supply / control	0.8 kV
	Control pollution degree	3
	Ambient temperature	-30...50 °C
Storage temperature	-40...80 °C	
Ambient humidity	Max. 95% r.H., non-condensing	
Servicing	maintenance-free	
<b>Weight</b>	Weight	1.4 kg
<b>Terms</b>	Abbreviations	POP = Power off position / fail-safe position PF = Power fail delay time / bridging time

## Safety notes



- The device must not be used outside the specified field of application, especially not in aircraft or in any other airborne means of transport.
- Outdoor application: only possible in case that no (sea) water, snow, ice, insolation or aggressive gases interfere directly with the actuator and that is ensured that the ambient conditions remain at any time within the thresholds according to the data sheet.
- Only authorised specialists may carry out installation. All applicable legal or institutional installation regulations must be complied during installation.
- The device may only be opened at the manufacturer's site. It does not contain any parts that can be replaced or repaired by the user.
- Cables must not be removed from the device.
- To calculate the torque required, the specifications supplied by the damper manufacturers concerning the cross-section, the design, the installation site and the ventilation conditions must be observed.
- Self adaption is necessary when the system is commissioned and after each adjustment of the angle of rotation (press the adaption push-button once).
- The device contains electrical and electronic components and must not be disposed of as household refuse. All locally valid regulations and requirements must be observed.

**Product features**

**Mode of operation** The actuator moves the damper to the desired operating position at the same time as the integrated capacitors are charged. Interrupting the supply voltage causes the damper to be rotated back into the fail-safe position by means of stored electrical energy.  
The actuator is connected with a standard modulating signal of 0...10 V and drives to the position defined by the positioning signal. Measuring voltage U serves for the electrical display of the damper position 0.5...100% and as a slave control signal for other actuators.

**Pre-charging time (start up)** The capacitor actuators require a pre-charging time. This time is used for charging the capacitors up to a usable voltage level. This ensures that, in the event of a power failure, the actuator can move at any time from its current position into the preset fail-safe position.  
The duration of the pre-charging time depends mainly on following factors:  
– Duration of the power failure  
– PF delay time (bridging time)

Typical pre-charging time

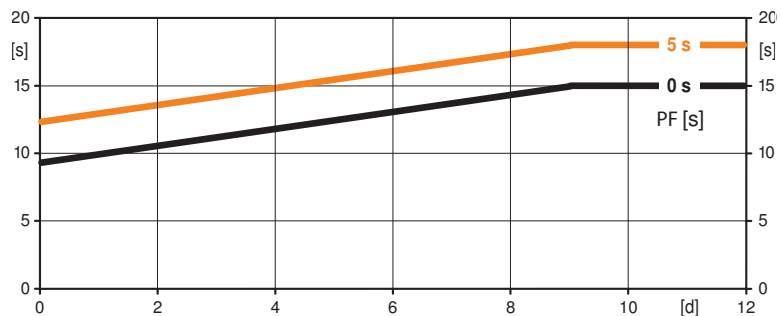

[d] = Electricity interruption in days  
[s] = Pre-charging time in seconds  
PF[s] = Bridging time

Calculation example: Given an electricity interruption of 3 days and a bridging time (PF) set at 5 s, the actuator requires a pre-charging time of 14 s after the electricity has been reconnected (see graphic).

PF [s]	[d]				
	0	1	2	7	≥10
0	9	10	11	13	15
5	12	13	14	16	18
[s]					

**Delivery condition (capacitors)** The actuator is completely discharged after delivery from the factory, which is why the actuator requires approximately 15 s pre-charging time before initial commissioning in order to bring the capacitors up to the required voltage level.

**Parametrisable actuators** The factory settings cover the most common applications. Single parameters can be modified with the Belimo Service Tools MFT-P or ZTH EU.

**Simple direct mounting** Simple direct mounting on the damper shaft with a universal shaft clamp, supplied with an anti-rotation device to prevent the actuator from rotating.

**Manual override** Manual control with push-button possible - temporary. The gear is disengaged and the actuator decoupled for as long as the button is pressed.

**Adjustable angle of rotation** Adjustable angle of rotation with mechanical end stops. A minimum permissible angle of rotation of 30° must be allowed for.

**High functional reliability** The actuator is overload protected, requires no limit switches and automatically stops when the end stop is reached.

**Home position** The first time the supply voltage is switched on, i.e. at the time of commissioning, the actuator carries out an adaption, which is when the operating range and position feedback adjust themselves to the mechanical setting range.  
The detection of the mechanical end stops enables a gentle approach to the end positions, thus protecting the actuator mechanics.  
The actuator then moves into the position defined by the positioning signal.

**Setting direction of rotation** When actuated, the direction of the rotation switch changes the running direction in normal operation. The direction of the rotation switch has no influence on the fail-safe position which has been set.

## Product features

<b>Setting fail-safe position (POP)</b>	<p>The rotary knob fail-safe position can be used to adjust the desired fail-safe position 0...100% in 10% increments.</p> <p>The rotary knob refers only to the adapted angle of rotation range 30°...95°. No set min. or max. values are observed.</p> <p>In the event of a power failure, the actuator will move into the selected fail-safe position, taking into account the bridging time that has been set.</p> <p>Settings: The rotary knob must be set to the «Tool» position for retroactive settings of the fail-safe position with the Belimo service tool MFT-P. Once the rotary knob is set back to the range 0...100%, the manually set value will have positioning authority.</p>
<b>Bridging time</b>	<p>Voltage interruptions can be bridged up to a maximum of 5 s. In the event of a voltage interruption, the actuator will remain stationary in accordance with the set bridging time. If the power failure is greater than the set bridging time, then the actuator drives into the selected fail-safe position.</p> <p>The bridging time set ex-works is 0 s. This can be modified on site in operation with the use of the Belimo service tool MFT-P.</p> <p>Settings: The rotary knob must not be set to the «Tool» position! Only the values need to be entered for retroactive adjustments of the bridging time with the Belimo service tool MFT-P.</p>
<b>Adaption and synchronisation</b>	<p>An adaption can be triggered manually by pressing the “Adaption” button or with the PC-Tool. Both mechanical end stops are detected during the adaption (entire setting range).</p> <p>A range of settings can be adapted using the PC-Tool (see MFT-P documentation)</p>

## Accessories

	Description	Type
<b>Electrical accessories</b>	Auxiliary switch 1 x SPDT add-on	S1A
	Auxiliary switch 2 x SPDT add-on	S2A
	Auxiliary switch 2 x SPDT add-on, grau	S2A/300 GR
	Auxiliary switch 2 x SPDT add-on, grau	S2A/500 GR
	Feedback potentiometer 140 Ω add-on	P140A
	Feedback potentiometer 140 Ω add-on, grau	P140A GR
	Feedback potentiometer 200 Ω add-on	P200A
	Feedback potentiometer 500 Ω add-on	P500A
	Feedback potentiometer 500 Ω add-on, grau	P500A GR
	Feedback potentiometer 1 kΩ add-on	P1000A
	Feedback potentiometer 1 kΩ add-on, grau	P1000A GR
	Feedback potentiometer 2.8 kΩ add-on	P2800A
	Feedback potentiometer 2.8 kΩ add-on, grau	P2800A GR
	Feedback potentiometer 5 kΩ add-on	P5000A
	Feedback potentiometer 5 kΩ add-on, grau	P5000A GR
	Feedback potentiometer 10 kΩ add-on	P10000A
	Feedback potentiometer 10 kΩ add-on, grau	P10000A GR
	Adapter for auxiliary switch and feedback potentiometer	Z-SPA
	Signal converter voltage/current 100 kΩ Supply AC/DC 24 V	Z-UIC
	Range controller for wall mounting	SBG24
	Positioner for wall mounting	SGA24
	Positioner for built-in mounting	SGE24
	Positioner for front-panel mounting	SGF24
Positioner for wall mounting	CRP24-B1	
Connection cable 5 m, A: RJ11 6/4 ZTH EU, B: 6-pin service socket for Belimo device	ZK1-GEN	
Connection cable 5 m, A: RJ11 6/4 ZTH EU, B: free wire end for connection to MP/PP terminal	ZK2-GEN	
	Description	Type
<b>Mechanical accessories</b>	Actuator arm for standard shaft clamp (one-sided)	AH-25
	Shaft extension 240 mm Ø20 mm for damper shaft Ø 8...22.7 mm	AV8-25
	Mounting kit for linkage operation for flat installation	ZG-NMA

Accessories

	Description	Type
<b>Service Tools</b>	Service Tool, with ZIP-USB function	ZTH EU
	Belimo PC-Tool, Software for adjustments and diagnostics	MFT-P
	Adapter for Service-Tool ZTH	MFT-C
	* Adapter Z-SPA It is imperative that this adapter will be ordered if an auxiliary switch or a feedback potentiometer is required.	

Electrical installation

**Notes**

- Connection via safety isolating transformer.
- Parallel connection of other actuators possible. Observe the performance data.

Wiring diagrams

AC/DC 24 V, modulating

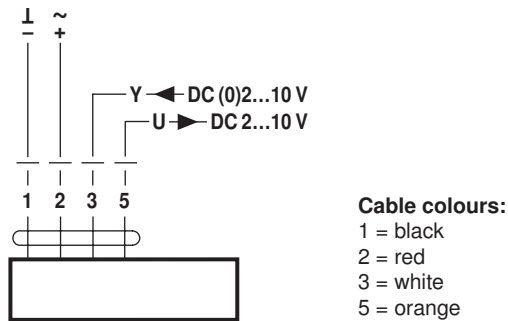

Parallel operation

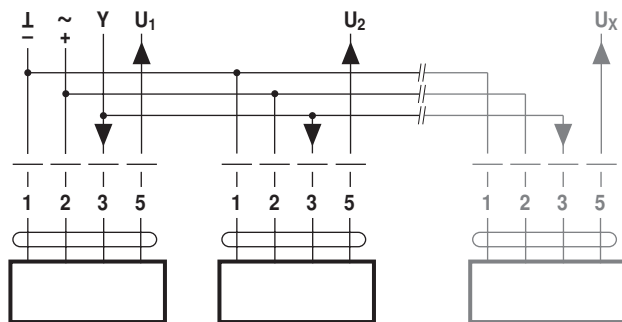

- Notes**
- A maximum of eight actuators can be connected in parallel.
  - Parallel operation is permitted only on non-connected axes.
  - Do not fail to observe performance data with parallel operation.

Signal cable lengths

L2 l / ~	Ltot = L1 + L2	
	AC	DC
0.75 mm <sup>2</sup>	≤30 m	≤5 m
1.00 mm <sup>2</sup>	≤40 m	≤8 m
1.50 mm <sup>2</sup>	≤70 m	≤12 m
2.50 mm <sup>2</sup>	≤100 m	≤20 m

- A = Actuator
- C = Control unit (controlling unit)
- L1 = Connecting cable of the actuator
- L2 = Customer cable
- Ltot = Maximum signal cable length

**Note:**  
When several actuators are connected in parallel, the maximum signal cable length must be divided by the number of actuators.

Electrical installation

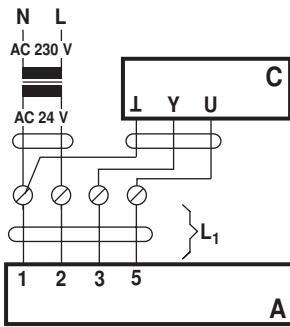

A = Actuator  
 C = Control unit (controlling unit)  
 L1 = Connecting cable of the actuator

**Note:**  
 There are no special restrictions on installation if the supply and the data cable are routed separately.

Functions

Functions with basic values (conventional mode)

Override control with AC 24 V with relay contacts

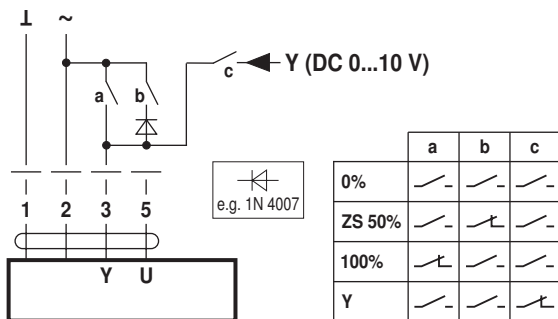

Override control with AC 24 V with rotary switch

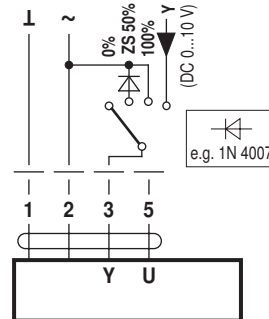

Control remotely 0...100% with positioner SG.. Minimum limit with positioner SG..

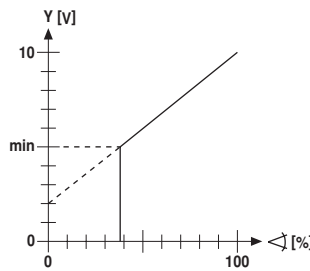
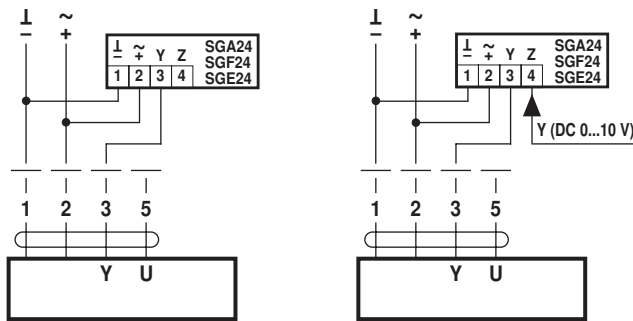

Control with 4...20 mA via external resistor

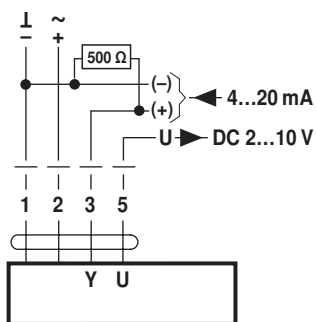

**Caution:**  
 The operating range must be set to DC 2...10 V.  
 The 500 Ω resistor converts the 4...20 mA current signal to a voltage signal DC 2...10 V

Functional check

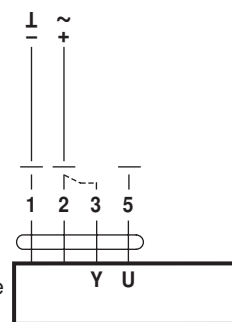

**Procedure**

1. Connect 24V to connections 1 and 2
2. Disconnect connection 3:
  - with direction of rotation 0: Actuator rotates to the left
  - with direction of rotation 1: Actuator rotates to the right
3. Short-circuit connections 2 and 3:
  - Actuator runs in opposite direction

Functions

Functions for devices with specific parameters (Parametrisation necessary)

Override control and limiting with AC 24 V with relay contacts

Override control and limiting with AC 24 V with rotary switch

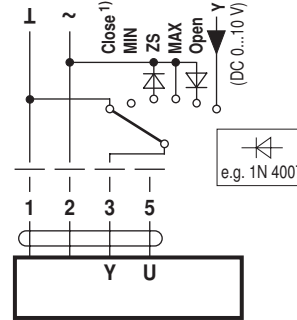
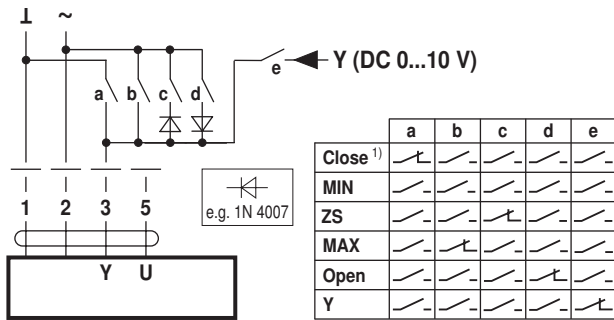

1) **Caution:** This function is only guaranteed if the start point of the operating range is defined as min. 0.5 V.

Control open/close

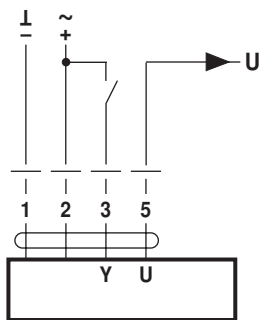

Control 3-point

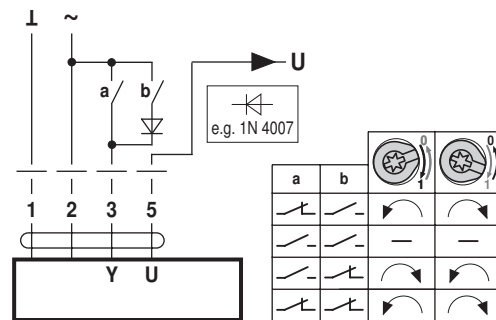

Operating controls and indicators

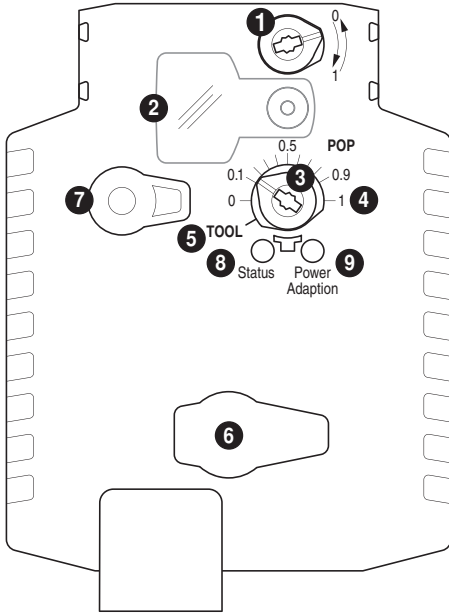

- 1 Direction of rotation switch
- 2 Cover, POP button
- 3 POP button
- 4 Scale for manual adjustment
- 5 Position for adjustment with tool
- 6 Tool socket
- 7 Disengagement button

LED displays		Meaning / function
8 yellow	9 green	
Off	On	Operation OK / without fault
Off	Flashing	POP function active
On	Off	Fault
Off	Off	Not in operation
On	On	Adaptation procedure running
Flashing	On	Communication with programming tool

- 9 **Press button:** Triggers angle of rotation adaption, followed by standard operation  
Setting emergency setting position (POP)

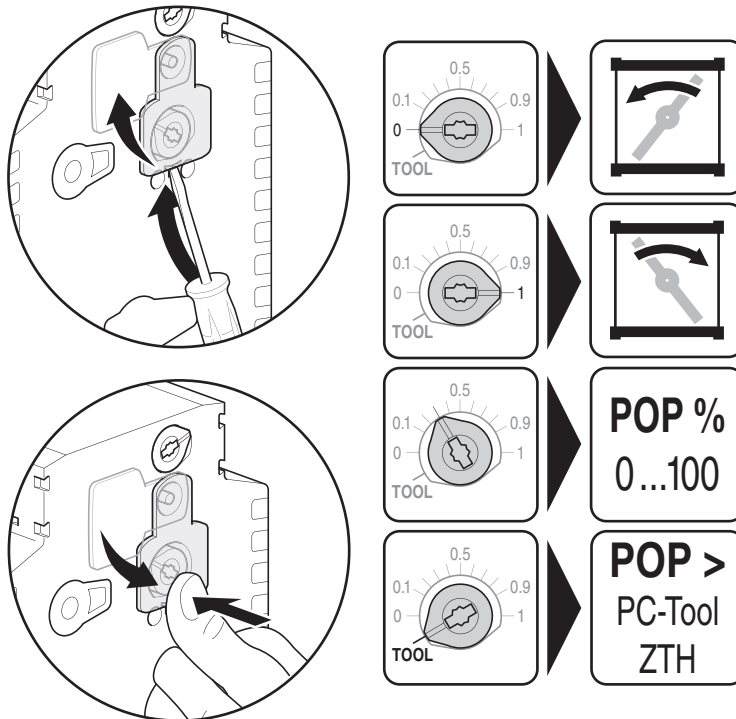



Service

**Service Tools connection** The actuator can be parametrised by ZTH EU via the service socket. For an extended parametrisation the PC tool can be connected.

Connection ZTH EU / PC-Tool

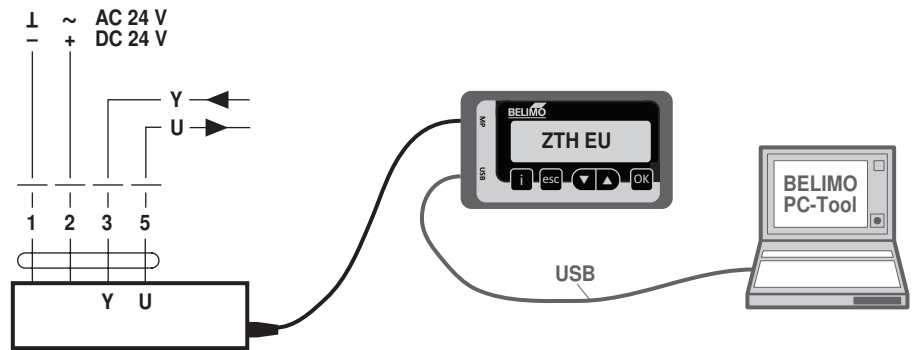

Dimensions [mm]

Spindle length

	Min. 42
	Min. 20

Clamping range

	8...26.7	≥8	≤26.7
	8...20	≥8	≤20

\*Option: Shaft clamp mounted below: If an auxiliary switch or a feedback potentiometer is used the adapter Z-SPA is required.

Dimensional drawings

